

the
futurebuild®
range

FUTUREBUILD®
STRUCTURAL LVL

hy
ONE®

FUTUREBUILD®
STRUCTURAL LVL

hy
SPAN®

FUTUREBUILD®
LVL TRUSS CHORDS

hy
CHORD®

FUTUREBUILD®
STRUCTURAL LVL
BEAMS

hy
90°

FUTUREBUILD®
LVL ENGINEERED
P-JOISTS

hy
JOIST®

FUTUREBUILD®
LVL SCAFFOLD
PLANKS

hy
PLANK®

FUTUREBUILD®
LVL FORMWORK
BEAMS

tru
FORM®

FUTUREBUILD®
LVL FORMWORK
EDGE BOARDS

edge
FORM®

FUTUREBUILD® LVL ENGINEERED I-JOISTS

hyJOIST®

HJ240 45 & HJ300 45

JULY 2018

Information contained within this manual is specific to the hyJOIST® range of LVL products and cannot be used with any other LVL products no matter how similar they may appear.

FUTUREBUILD®
LVL ENGINEERED
I-JOISTS

hyJOIST®

Contents

1.0	Introduction.....	3
1.1	Health & Safety.....	4
1.2	Storage & Handling.....	4
2.0	General.....	4
3.0	Bearing Requirements.....	5
4.0	Lateral Restraint.....	5
5.0	Floor Joists Under Walls.....	6
6.0	Holes & Notches in Floor Joists.....	7
7.0	Structural Certification.....	7
7.1	Technical Basis for Structural Design Methodology.....	7

hyJOIST 44974

EMPOD JOIS-DNZ 24-05-16 11:42 HTL
DO NOT CUT OR BORE TOP OR BOTTOM

1.0 INTRODUCTION

Futurebuild® has added two sizes to the hyJOIST® range of LVL for the New Zealand market.

When supporting floor loads only, the hyJOIST HJ240 45 and HJ300 45 have similar or increased spanning capability to 240 x 45 SG8 and 290 x 45 SG8 respectively. The hyJOIST range of products have the additional benefit of allowing for the cutting of large web holes at defined locations, providing easy installation of plumbing and ventilation ducts within the floor cavity, and avoiding the need for dropped ceilings or bulkheads.

Other cost saving features made possible by the straightness and uniformity of hyJOIST include no mid span blocking and no packing or planning to achieve a level floor.

hyJOIST HJ240 45 and HJ300 45 are a lightweight solution, approximately 70% and 64% of the weight of the 240 x 45 and 290 x 45 SG8 joists respectively. hyJOIST products are branded with the EWPAA quality assurance stamp, thereby demonstrating that the product has been made in a quality controlled environment, at our LVL mill at Marsden Point.

hyJOIST LVL must be installed in accordance with good building practice and sound design principles. This is the responsibility of building owners and design professionals and the builders that they engage. This document contains information, limitations and cautions regarding storage, handling, installation, usage and maintenance of hyJOIST. However, Futurebuild assumes no legal liability to you in relation to this information.

The information contained in this document is current as at July 2018. It is your responsibility to ensure you have the most up to date information available.

The information contained in this publication relates specifically to hyJOIST® LVL products manufactured by Futurebuild® and must not be used with any other LVL manufacturer's products no matter how similar they may appear.

Alternative LVL products can differ in a number of ways which may not be immediately obvious and substituting them for hyJOIST® LVL products is not appropriate, and could in extreme cases lead to premature failure and/or buildings which do not meet the requirements of the NZBC.

1.1 HEALTH & SAFETY

Futurebuild® LVL should be handled in accordance with the Safety Data Sheets (SDS) for untreated and H1.2 treated LVL, which are available upon request from Futurebuild. Always wear safety glasses or non-fogging goggles when machining Futurebuild LVL.

If wood dust exposures are not controlled when machining

(sawing, routing, planing, drilling etc.) a class P1 or P2 replaceable filter or disposable face piece respirator should be worn. Wear comfortable work gloves to avoid skin irritation and the risk of splinters. Wash hands with mild soap and water after handling Futurebuild LVL.

1.2 STORAGE & HANDLING

Futurebuild LVL requires care in storage and handling. The following suggestions will help keep the Futurebuild LVL in good condition before use and after installation.

The storage area should be protected from sun, rain and wind that can bring about rapid changes in temperature and humidity.

- Supports of the Futurebuild® LVL should be provided at both ends and middle to avoid distortion. Ensure bearers in packs above are aligned over the bearers below (to avoid inducing curves in the joist).

- Prior to installation Futurebuild LVL should be stacked vertically on level bearers, at least 150mm clear of the ground.
- Futurebuild LVL should be kept clear of any ponding on the floor and placed so that it is not exposed to mechanical damage, and is kept as dry as practicable.
- Futurebuild LVL should be kept covered where possible, minimising any exposure to weather.

2.0 GENERAL

The information in this document is specific to hyJOIST® HJ240 45 and HJ300 45 and should be read in conjunction with the hyJOIST Design & Installation Guide: 2.1. Where conflict exists between these two documents the information contained in this document takes priority.

The following span table relates to the spanning capability of hyJOIST HJ240 45 and HJ300 45 products supporting floor live loads not exceeding 1.5kPa/1.8kN.

hyJOIST HJ240 45 and HJ300 45 may be directly substituted for 240 x 45 SG8 and 290 x 45 SG8 as specified in NZS 3604:2011 when supporting floor loads only, providing they do not form part of an external situation. Some subtle differences apply between the installation of hyJOIST and installation of SG8. These differences are detailed below and within the hyJOIST Design & Installation Guide 2.1.

Table 1: Floor Joists Supporting Floor Loads Only (1.5kPa/1.8kN)

Section	Product	Maximum single span of floor joists at a maximum spacing (mm) of:		
		400	450	600
240 x 45 ¹	SG8	4.40	4.30	3.90
HJ240 45 ²	hyJOIST®	4.70	4.30	4.00
290 x 45 ¹	SG8	5.20	5.05	4.60
HJ300 45 ²	hyJOIST	5.35	5.15	4.80

1. SG8 spans as per NZS 3604 Table 7.1(a) Floor joists.

2. hyJOIST® spans determined using designT® for houses software.

3.0 BEARING REQUIREMENTS

Where floor joists are supporting floor loads, the floor joists shall have a minimum bearing of 30mm at their supports. For floor joists supporting load bearing walls at supports, refer to Table 2. Alternatively, install continuous hyJOIST® blocking/rimboard/ boundary joist beneath the load bearing wall.

Joints in floor joists may be butted over supports provided that, in cases detailed in NZS 3604:2011 Clause 7.1.1.6, joists are flitched using a plywood flitch plate as detailed in Detail F23.

Table 2: Minimum Bearing Requirements for hyJOIST® HJ240 45 and HJ300 45 Supporting Load Bearing Walls at Supports

Floor Joist Spacing	Roof Type	
	Light Roof and Ceiling	Heavy Roof and Ceiling
450mm	45mm	65mm
600mm	65mm	90mm

Figure 23: Flitch Joist in Joist

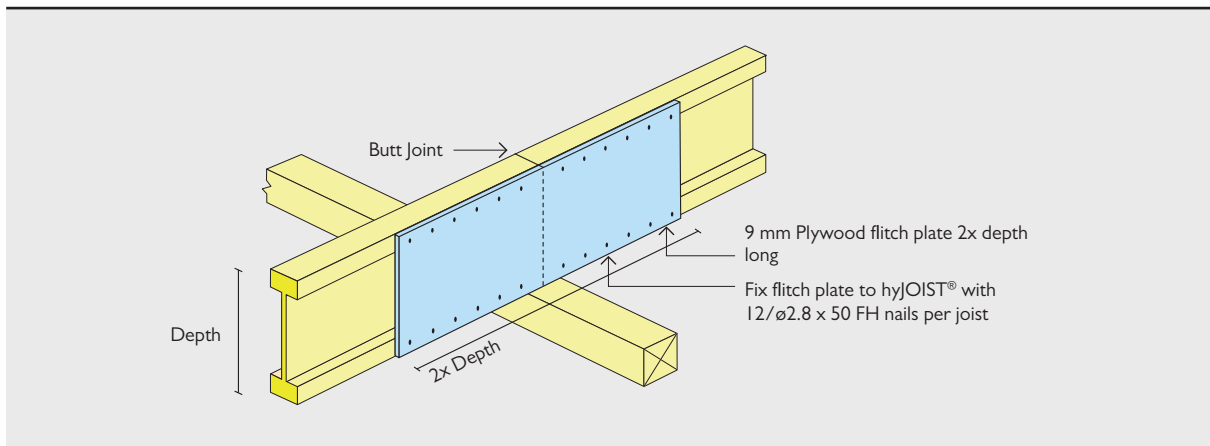

4.0 LATERAL RESTRAINT

Intermittent Blocking (or Equivalent) at Supports

The fundamental requirement is to install joists plumb and hold them upright at supports. The simplest and most effective way of achieving this is to install square cut hyJOIST® blocking but alternative methods such as the use of 'rimboard', boundary joists, metal strap/brace or plywood closures are acceptable.

For installation of blocking, 'rimboard', boundary joist, metal strap/brace or plywood enclosures refer to Details F1, F2, F3 and F17 in the hyJOIST Design & Installation Guide: 2.1, designIT® for houses software or designIT site smartphone APPs.

Figure 1

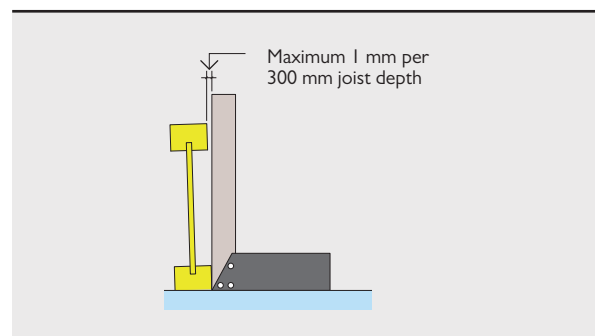
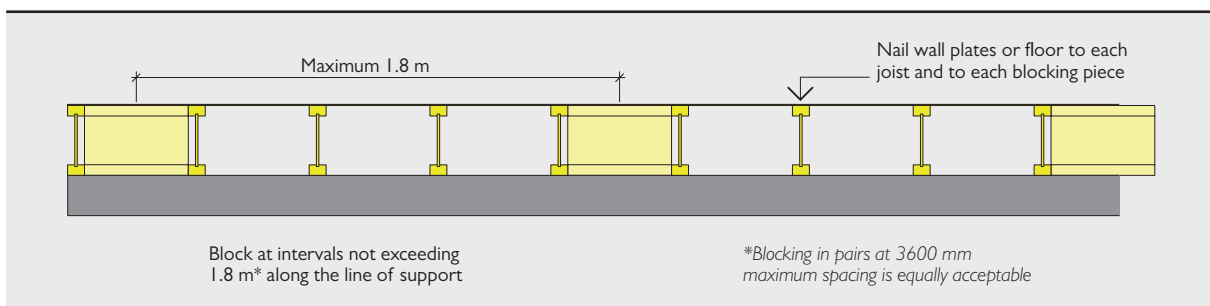

Figure 2



Intermediate Restraint (Between Supports)

For best performance, the top flange of hyJOIST® should be held straight between supports – (no more than 1 mm per metre of span deviation from straight).

Before loading joists and attachment of flooring:

- Install blocking (or equivalent) at supports as described above, and between supports, install temporary battens braced back to a point of rigidity (no more than 2.5 metres apart) to hold the top flange of each joist straight between supports.
- For installation of flooring, progressively work across the floor removing battens as required.

Note: Intermediate blocking is not required and can be a source of annoying nail creaks in the finished structure.

Figure 3

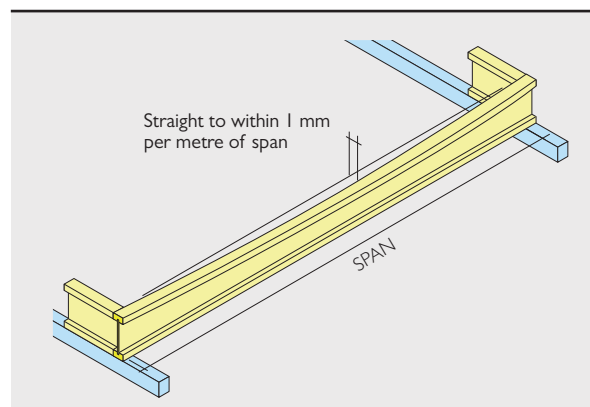
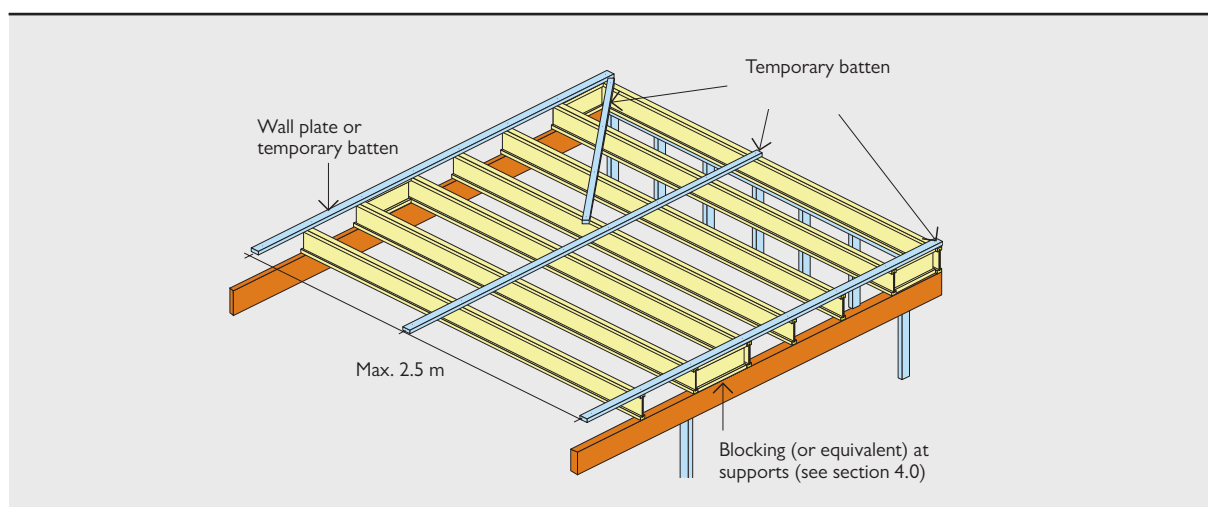

Figure 4



5.0 FLOOR JOISTS UNDER WALLS

Where a load bearing wall runs parallel to the line of floor joists beneath, support it with a pair of floor joists as detailed in NZS 3604:2011 Clause 7.1.3.1 with maximum spans as detailed below. Floor joists supporting parallel load bearing walls over large spans can deflect excessively even if the 'rule of thumb' practice of doubling joists is followed. The following tables give maximum spans for double joists for various roof

load widths, please confirm the design spans are suitable for the imposed loads.

The following span tables relates to the spanning capability of 2/HJ240 45 and 2/HJ300 45 products supporting roof load widths as detailed for ground snow loads up to and including 0.9kPa and design wind regions up to and including very high.

Table 3: Joists Supporting Parallel Load Bearing Walls

hyJOIST® Section Code	Roof Load Width (m)					
	1.8	2.4	3.6	4.8	6.0	7.2
	Maximum Single Span (m)					
	Light Roof and Ceiling (40kg/m²)					
2/HJ240 45	4.1	3.9	3.5	3.3	2.9	2.4
2/HJ300 45	4.8	4.6	4.2	3.9	3.7	3.1
	Heavy Roof and Ceiling (90kg/m²)					
2/HJ240 45	3.4	3.1	2.7	2.4	2.0	1.7
2/HJ300 45	4.1	3.8	3.3	3.0	2.6	2.2

6.0 HOLES & NOTCHES IN FLOOR JOISTS

Holes may be cut through the web of hyJOIST® provided they are located within the central part of the span as specified below. For hole sizes other than those included below, including square/rectangular holes, refer to the web hole calculator in the

designIT® site smartphone APPs. For cases involving non-uniform loading or where the possibility of locating the hole closer to supports needs to be assessed, contact the Futurebuild® Team.

Figure 5 Circular Holes

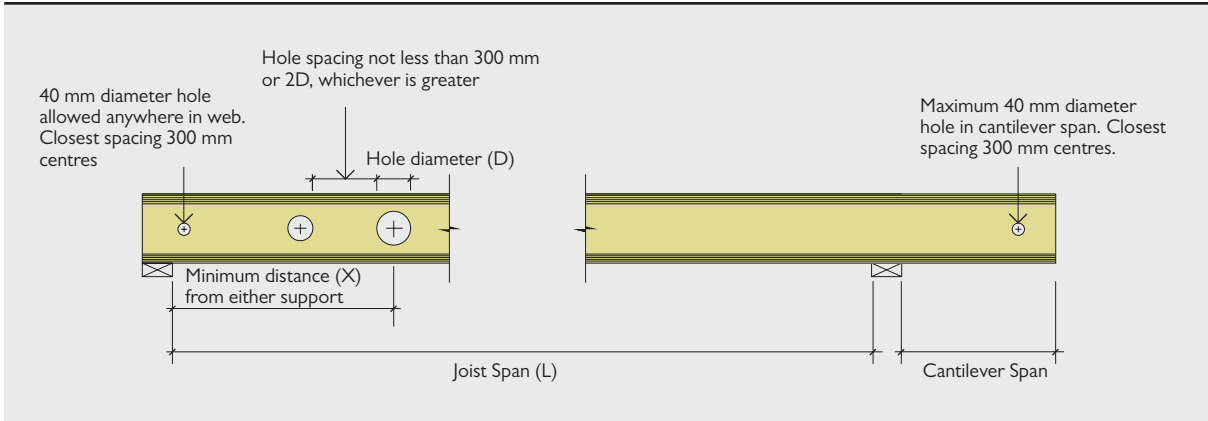

Table 4: Web Holes for hyJOIST®

hyJOIST® Section Code	Maximum Hole Diameter (mm)	Minimum Distance from Support 'X'	Hole Diameter (mm)			
			80	110	125	150
			Circular Holes - Minimum Distance 'X' from Support (m)			
HJ240 45	147	0.38L	0.12L	0.21L	0.26L	
HJ300 45	207	0.41L	0.10L	0.15L	0.18L	0.24L

* Minimum distance from any support is 0.3 metres.

Notes:

1. Data applies for floor joists supporting uniform loads (and concentrated live load not exceeding 1.8kN).
2. Hole locations closer to supports may be possible for some load and support conditions; contact Futurebuild®.
3. Spacing between holes to be not less than 300mm or twice the diameter of the larger hole, whichever is greater.
4. Not more than three holes with width or diameter greater than 80mm in any span.
5. For cantilever spans holes greater than 40mm diameter are not permitted.
6. Not more than one rectangular (or square) hole per span.

Figure 6

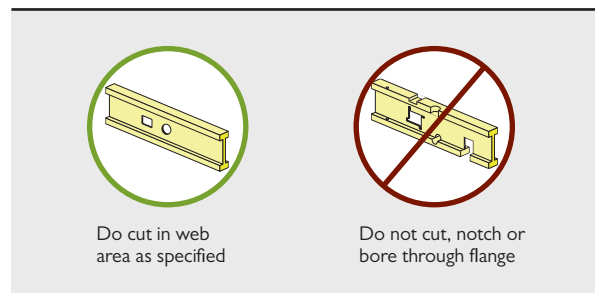

7.0 STRUCTURAL CERTIFICATION

7.1 TECHNICAL BASIS FOR STRUCTURAL DESIGN METHODOLOGY

The design methodology used in the development of the span tables within this brochure complies with the loading and general design requirements contained within AS/NZS 1170:2002 (including amendments) and with timber structural design in accordance with NZS 3603:1993 including Amendment 4

(Verification method B1/VM1, 6.1). The sizes and spans given will comply with the structural requirements of the New Zealand Building Code, provided the installation is in accordance with the installation requirements and good building practice, as appropriate.

the futurebuild® range

the futurebuild® range

Private Bag 92-106
Victoria Street West
Auckland 1142
New Zealand

Freephone: 0800 808 131
Freefax: 0800 808 132

www.futurebuild.co.nz
www.chsoftware.com

July 2018

