

Outrigger installed in contact with hyJOIST support and timber block

Timber block of thickness to match hyJOIST flange thickness

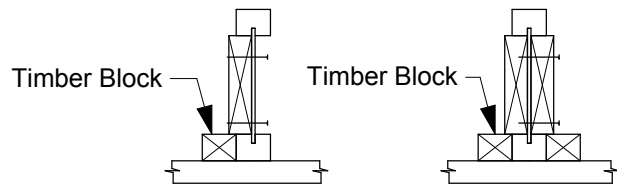

Section A-A

Double outrigger nailing to match as shown for single outrigger

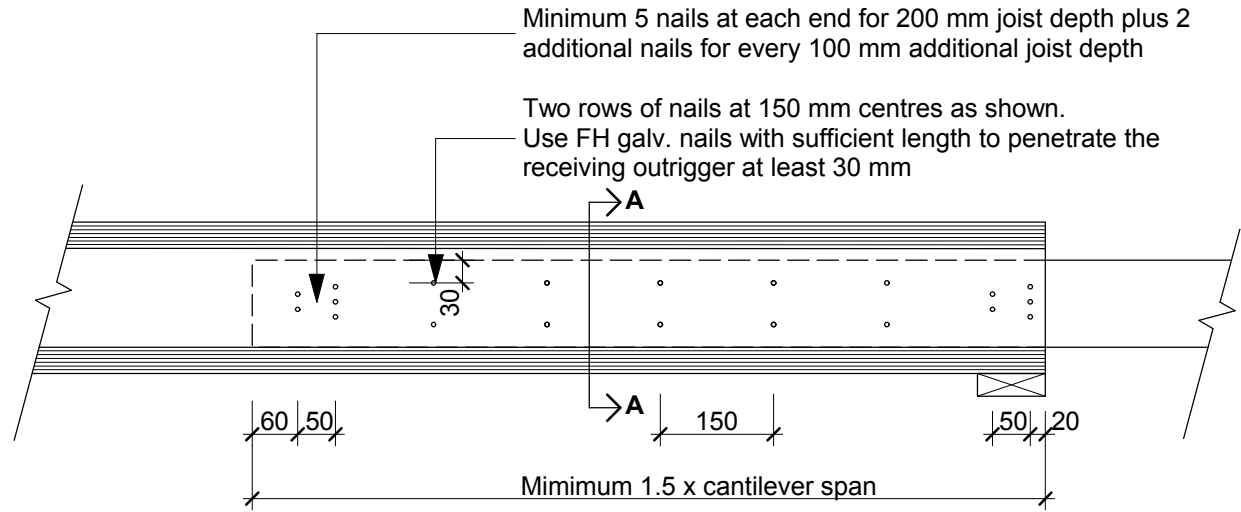

## Detail F12

Nested outrigger installation

May 2007

### Futurebuild hyJOIST Construction Details

Construction details "Copyright" to Carter Holt Harvey Limited  
Supplied for use by building design professionals in New Zealand